

	Series Sleeve Color	Type	Features	Operating Temperature Range	Working Voltage	Capacitance	Leakage Current	Endurance Hours	Page
Conductive Polymer	PL	Radial	Very low ESR	-55 to +105 °C	2.5~16V	180~3500µF	≤ 0.2CV	2000	26
	PS	Radial	Standard	-55 to +105 °C	2.5~25V	39~3500µF	≤ 0.2CV	2000	29
	PU	Radial	Ultra low ESR	-55 to +105 °C	2.5~10V	180~3500µF	≤ 0.2CV	2000	34
	PX	Radial	Low profile	-55 to +105 °C	2.5~25V	10~820µF	≤ 300µA	2000	37
	PE	Radial	Ultra low ESR, Down size to 6.3X8 (mm)	-55 to +105 °C	2.5~6.3V	470~820µF	≤ 0.2CV	2000	41
	PW	Radial	Low height 2000Hours	-55 to +105 °C	2.5V~25V	39~2500µF	≤ 0.2CV	2000	42
	PH	Radial	High Voltage/High Reliability	-55 to +105 °C	35V~50V	10~150µF	≤ 0.2CV	2000	45
	PT	Radial	125 °C Guaranteed	-55 to +125 °C	2.5~16V	180~2500µF	≤ 0.2CV	2000	47
	PF	Radial	Long Life to 5,000Hours	-55 to +105 °C	2.5~16V	100~2700µF	≤ 0.2CV	5000	50
	PM	SMD	SMD & Low profile	-55 to +105 °C	2.5~25V	10~560µF	≤ 300µA	2000	53
	PD	SMD	SMD & Large capacitance	-55 to +105 °C	2.5~25V	39~3300µF	≤ 0.2CV	2000	56
	PV	SMD	SMD & Low height	-55 to +105 °C	2.5~25V	39~2500µF	≤ 0.2CV	2000	59
SMD type	EV	SMD	105 °C, Standard	-55 to +105 °C	6.3~50V	0.1~1500µF	0.01CV or 3µA	1000	62
	LV	SMD	85 °C, Standard	-40 to +85 °C	4~50V	0.1~6800µF	0.01CV or 3µA	2000	64
	HV	SMD	Wide temperature range	-55 to +105 °C	6.3~63V	0.1~6800µF	0.01CV or 3µA	2000	66
	JV	SMD	3000 hours life	-55 to +105 °C	6.3~50V	0.1~1000µF	0.01CV or 3µA	3000	68
	MV	SMD	5000 hours life	-40 to +105 °C	6.3~50V	0.1~1000µF	0.01CV or 3µA	5000	70
	NV	SMD	5.5 ~ 10.5mm height, Non-polar	-40 to +85 °C	6.3~50V	0.1~560µF	0.05CV or 10µA	2000	72
	KV	SMD	85 °C, Low leakage current	-40 to +85 °C	6.3~50V	0.1~330µF	0.002CV or 0.4µA	1000	74
	ZV	SMD	105 °C, Low impedance	-55 to +105 °C	6.3~50V	1~6800µF	0.01CV or 3µA	2000 ~ 5000	76
	DV	SMD	105 °C, Low impedance	-55 to +105 °C	6.3~50V	1~6800µF	I ≤ 0.01CV or 3µA	2000 ~ 5000	78
	RV	SMD	105 °C, Low impedance, LongLife	-55 to +105 °C	6.3~50V	1~6800µF	I ≤ 0.01CV or 3µA	2000 ~ 5000	80
TV	SMD	For high temperature + 125 °C	-40 to +125 °C	10~50V	10~330µF	0.03CV or 4µA	1000 ~ 2000	82	
Ultra-miniature type	SS	Radial	5mm, Standard, 85 °C	-40 to +85 °C	4~50V	0.1~330µF	0.01CV or 3µA	1000	84
	ST	Radial	5mm, Standard, 105 °C	-40 to +105 °C	4~50V	0.1~100µF	0.01CV or 3µA	1000	86
	SA	Radial	5mm, Low leakage current	-40 to +85 °C	4~50V	0.1~100µF	0.002CV or 0.4µA	1000	88
	SP	Radial	5mm, Non-polar	-40 to +85 °C	6.3~50V	0.1~47µF	0.05CV or 10µA	1000	90
	SM	Radial	7mm, Standard, 85 °C	-40 to +85 °C	4~63V	0.1~470µF	0.01CV or 3µA	1000	92
	SH	Radial	7mm, 85 °C, Long life	-40 to +85 °C	4~63V	0.1~470µF	0.01CV or 3µA	2000	94
	SK	Radial	7mm, Standard, 105 °C	-40 to +105 °C	4~63V	0.1~470µF	0.01CV or 3µA	1000	96
	SJ	Radial	7mm, 105 °C, Long life 2000 hours	-40 to +105 °C	6.3~63V	0.1~220µF	0.01CV or 3µA	2000	98
	SG	Radial	7mm, 105 °C, Long life 4000 hours	-40 to +105 °C	6.3~50V	0.1~470µF	0.01CV or 3µA	4000	100
	SL	Radial	7mm, Low leakage current, 85 °C	-40 to +85 °C	6.3~50V	0.1~220µF	0.002CV or 0.4µA	1000	102
	SD	Radial	7mm, Low leakage current, 105 °C	-40 to +105 °C	4~63V	0.1~100µF	0.002CV or 0.4µA	1000	104
	SN	Radial	7~ 9mm, Non-polar, 85 °C	-40 to +85 °C	6.3~50V	0.1~220µF	0.05CV or 10µA	1000	106
	SB	Radial	7mm, Non-polar, 105 °C	-40 to +105 °C	6.3~50V	0.1~100µF	0.05CV or 10µA	1000	108
	SZ	Radial	7mm, Low impedance	-55 to +105 °C	6.3~35V	6.8~330µF	0.01CV or 3µA	1000	110
SY	Radial	7mm, Low impedance, Long life	-55 to +105 °C	6.3~50V	1~330µF	0.01CV or 3µA	2000	112	
Standard type	GS (GR)	Radial	General purpose, 85 °C	-40 to +85 °C -25 to +85 °C	6.3~100V 160~450V	0.1~33000µF 0.47~470µF	0.01CV or 3µA 0.03CV	2000	114
	GW	Radial	9~21mm height low profile, 85 °C	-40 to +85 °C -25 to +85 °C	6.3~100V 160~450V	2.2~10000µF 2.2~220µF	0.01CV or 3µA 0.04CV + 100µA	2000	118
	KM	Radial	Standard, 105 °C	-40 to +105 °C -25 to +105 °C	6.3~100V 160~450V	0.1~22000µF 0.47~470µF	0.01CV or 3µA 0.03CV	2000	120
	KW	Radial	9~21mm height low profile, 105 °C	-40 to +105 °C -25 to +105 °C	6.3~100V 160~450V	2.2~10000µF 1.5~220µF	0.01CV or 3µA 0.04CV + 100µA	2000	124
	KC	Radial	Ultra Miniaturized	-25 to +105 °C	400~450V	82~220µF	I ≤ 3 √CV	3000	126
	LL	Radial	Low leakage current	-40 to +105 °C	6.3~63V	0.1~2200µF	0.002CV or 0.4µA	2000	128
Low Impedance / ESR type	GL	Radial	Low impedance and Low ESR Miniaturized	-55 to +105 °C	6.3~63V	0.47~10000µF	0.01CV or 3µA	2000 ~ 6000	130
	KF	Radial	Low impedance for power supply	-40 to +105 °C -25 to +105 °C	6.3~100V 160~450V	0.47~15000µF 0.47~220µF	0.01CV or 3µA 0.03CV	2000 ~ 5000	133
	KZ	Radial	Low impedance	-40 to +105 °C	6.3~50V	0.47~6800µF	0.01CV or 3µA	1000 ~ 2000	138
	GF	Radial	Low impedance	-55 to +105 °C	6.3V~100V	4.7~6800µF	0.01CV or 3µA	2000 ~ 5000	141
	LZ	Radial	Ultra low ESR and High ripple current	-40 to +105 °C	6.3~25V	220~3300µF	0.01CV or 3µA	2000	146
GH	Radial	High temperature and Long life	-55 to +105 °C	6.3~50V	0.47~6800µF	0.01CV or 3µA	3000 ~ 10000	148	

	Series Sleeve Color	Type	Features	Operating Temperature Range	Working Voltage	Capacitance	Leakage Current	Endurance Hours	Page
High reliability type	FH	Radial	Ultra Low ESR and Long Life	-40 to +105 °C	6.3V~100V	22~5600µF	0.01CV or 3µA	4000 ~ 10000	151
	KL	Radial	Long life 5,000 hours	-25 to +105 °C	160~450V	10~220µF	0.04CV + 100µA	5000	155
	KH	Radial	Long life 5,000~10,000 hours	-40 to +105 °C -25 to +105 °C	10~50V 160~450V	6.8~3300µF 6.8~220µF	0.01CV or 3µA 0.04CV + 100µA	5000 ~ 10000	157
	TH	Radial	For high temperature +125 °C	-40 to +125 °C -25 to +125 °C	10~100V 160~350V	0.47~1000µF 1~100µF	0.01CV or 3µA 0.02CVµA	1000 ~ 2000	159
	TE	Radial	For high temperature +130 °C	-40 to +130 °C	10~50V	3.3~4700µF	0.01CV or 3µA	2000 ~ 3000	161
	KS	Radial	Over voltage vent operating facility	-25 to +105 °C	200,400WV	4.7~470µF	0.03CV	2000	163
	FK	Radial	Long life for LED and ballast	-25 to +105 °C	160~450WV	1~330µF	0.04CV+100µA	6000 ~ 8000	165
	FL	Radial	Long life for LED and ballast	-25 to +105 °C	160~450WV	1~330µF	0.04CV+100µA	8000 ~ 10000	167
	LE	Radial	Long life for LED lighting	-25 to +105 °C	160~450WV	1~68µF	0.04CV+100µA	10000 ~ 15000	169
	KY	Radial	Slim type	-25 to +105 °C	250~450WV	10~150µF	$I \leq 3 \sqrt{CV}$	2000	171
	LY	Radial	Slim type, longlife 5000hours	-25 to +105 °C	250~450WV	10~150µF	$I \leq 3 \sqrt{CV}$	5000	173
	HY	Radial	Slim type, longlife 10000hours	-25 to +105 °C	250~450WV	12~120µF	$I \leq 3 \sqrt{CV}$	10000	175
Non/bi polarized type	NP	Radial	Non-polarized, 85 °C	-40 to +85 °C -25 to +85 °C	6.3~100V 160~250V	0.47~3300µF 0.47~47µF	0.03CV or 3µA	2000	177
	NK	Radial	Non-polarized, 105 °C	-40 to +105 °C -25 to +105 °C	6.3~100V 160~250V	0.47~3300µF 0.47~47µF	0.03CV or 3µA	2000	179
	BP	Radial	Bi-polarized	-40 to +105 °C	25/50/63V	2.2~15µF	100µA	2000	181
For Audio Equipment	SW	Radial	5mm height, for audio equipment	-40 to +85 °C	4~50V	0.1~470µF	0.01CV or 3µA	1000	183
	SR	Radial	7mm height, for audio equipment	-40 to +85 °C	6.3~50V	0.1~220µF	0.01CV or 3µA	1000	185
	RW	Radial	Standard, for audio equipment	-40 to +85 °C	6.3~100V	0.1~33,000µF	0.01CV or 3µA	2000	187
	NR	Radial	Non-polar, for audio equipment	-40 to +85 °C	6.3~100V	0.47~1,000µF	0.03CV or 3µA	2000	189
	LR	Snap-in	85 °C, for audio equipment	-40 to +85 °C	16~100V	680~33,000µF	0.02CVµA	2000	191
Large can type	LP	Snap-in	85 °C, Standard	-40 to +85 °C -25 to +85 °C	10~100V 160~450V	470~68000µF 47~2700µF	0.02CVµA	2000	196
	LS	Snap-in	85 °C, Miniaturized	-25 to +85 °C	160~450V	47~2700µF	0.02CVµA	2000	200
	LU	Snap-in	85 °C, Longlife 3000hours	-40 to +85 °C -25 to +85 °C	16~100V 160~450V	820~47000µF 56~2700µF	$I \leq 3 \sqrt{CV}$	3000	203
	HP	Snap-in	105 °C, Standard	-40 to +105 °C -25 to +105 °C	10~100V 160~450V	330~68000µF 33~2200µF	0.02CVµA	2000	207
	HS	Snap-in	105 °C, Miniaturized	-25 to +105 °C	160~450V	33~2700µF	0.02CVµA	2000	211
	HW	Snap-in	105 °C, Low Profile 15mm height	-25 to +105 °C	160~400V	39~390µF	$I \leq 3 \sqrt{CV}$	2000	214
	HU	Snap-in	105 °C, Longlife 3000hours	-40 to +105 °C -25 to +105 °C	16~100V 160~450V	560~47000µF 47~2700µF	$I \leq 3 \sqrt{CV}$	3000	216
	HL	Snap-in	Long life with low ESR	-40 to +105 °C -25 to +105 °C	10~100V 160~400V	560~47000µF 56~1500µF	0.02CVµA	5000	220
	LT	Snap-in	4 Snap-in terminals type	-40 to +85 °C -25 to +85 °C	16~100V 160~450V	4700~82000µF 330~3300µF	0.02CVµA	2000	225
	HT	Snap-in	4 Snap-in terminals type	-25 to +105 °C	160~400V	82~1200µF	0.02CVµA	2000	227
For inverter air conditioner	UB	Snap-in	Useful life 4000hours	-25 to +85 °C	400~450V	330~1200µF	$I \leq 3 \sqrt{CV}$	2000	229
	UC	Snap-in	Useful life 6000hours	-25 to +85 °C	400~450V	330~1200µF	$I \leq 3 \sqrt{CV}$	3000	231
	UD	Snap-in	Useful life 10000hours	-25 to +85 °C	400~450V	330~1200µF	$I \leq 3 \sqrt{CV}$	5000	233
	UJ	Snap-in	Useful life 3000hours	-25 to +105 °C	400~450V	330~1200µF	$I \leq 3 \sqrt{CV}$	2000	235
	UK	Snap-in	Useful life 5000hours	-25 to +105 °C	400~450V	330~1200µF	$I \leq 3 \sqrt{CV}$	3000	237
	UL	Snap-in	Useful life 7000hours	-25 to +105 °C	400~450V	330~1000µF	$I \leq 3 \sqrt{CV}$	5000	239
Photo flash type	RF	Radial	Photo flash equipment	-20 to +55 °C	330/350V	100~450µF	1XCµA	5000times	241
	SF	Snap-in	Photo flash equipment	-20 to +55 °C	330/350V	150~1500µF	1XCµA	5000times	242
Screw large can type	RS	Screw	General	-40 to +85 °C	16~100V	3300~1000000µF	$\leq 0.3\mu A * (C * V)^{0.7} + 4\mu A$	2000	261
	RG	Screw	Useful life 6000hours	-25 to +85 °C	160~450V	680~68000µF	$\leq 0.3\mu A * (C * V)^{0.7} + 4\mu A$	2000	264
	RP	Screw	Useful life 10000hours	-25 to +85 °C	160~450V	680~68000µF	$\leq 0.3\mu A * (C * V)^{0.7} + 4\mu A$	2000	269
	RX	Sxrew	useful life 20000hours	-25 to +85 °C	160~450V	220~47000µF	$\leq 0.3\mu A * (C * V)^{0.7} + 4\mu A$	5000	274
	RU	Screw	useful life 12000hours high ripple current	-25 to +85 °C	350~450V	1000~22000µF	$\leq 0.3\mu A * (C * V)^{0.7} + 4\mu A$	2000	278
	RJ	Screw	useful life 10000hours with stud	-25 to +85 °C	350~450V	1500~22000µF	$\leq 0.3\mu A * (C * V)^{0.7} + 4\mu A$	2000	282
	RY	Screw	useful life 12000hours high ripple current with stud	-25 to +85 °C	350~450V	1500~22000µF	$\leq 0.3\mu A * (C * V)^{0.7} + 4\mu A$	2000	286
	RK	Screw	General	-40 to +105 °C	16~100V	1500~1000000µF	$\leq 0.3\mu A * (C * V)^{0.7} + 4\mu A$	2000	290
	RL	Screw	Long life	-25 to +105 °C	350~450V	680~15000µF	$\leq 0.3\mu A * (C * V)^{0.7} + 4\mu A$	5000	293
	RM	Screw	useful life 6000hours	-25 to +105 °C	160~450V	220~47000µF	$\leq 0.3\mu A * (C * V)^{0.7} + 4\mu A$	2000	296
	RH	Screw	useful life 8000hours high ripple current	-25 to +105 °C	160~450V	220~47000µF	$\leq 0.3\mu A * (C * V)^{0.7} + 4\mu A$	2000	300
	RQ	Screw	useful life 6000hours with stud	-25 to +105 °C	160~450V	2200~47000µF	$\leq 0.3\mu A * (C * V)^{0.7} + 4\mu A$	2000	304
	RT	Screw	useful life 8000hours high ripple current with stud	-25 to +105 °C	160~450V	2200~47000µF	$\leq 0.3\mu A * (C * V)^{0.7} + 4\mu A$	2000	308

Conductive Polymer AL.E. Capacitors Radial type

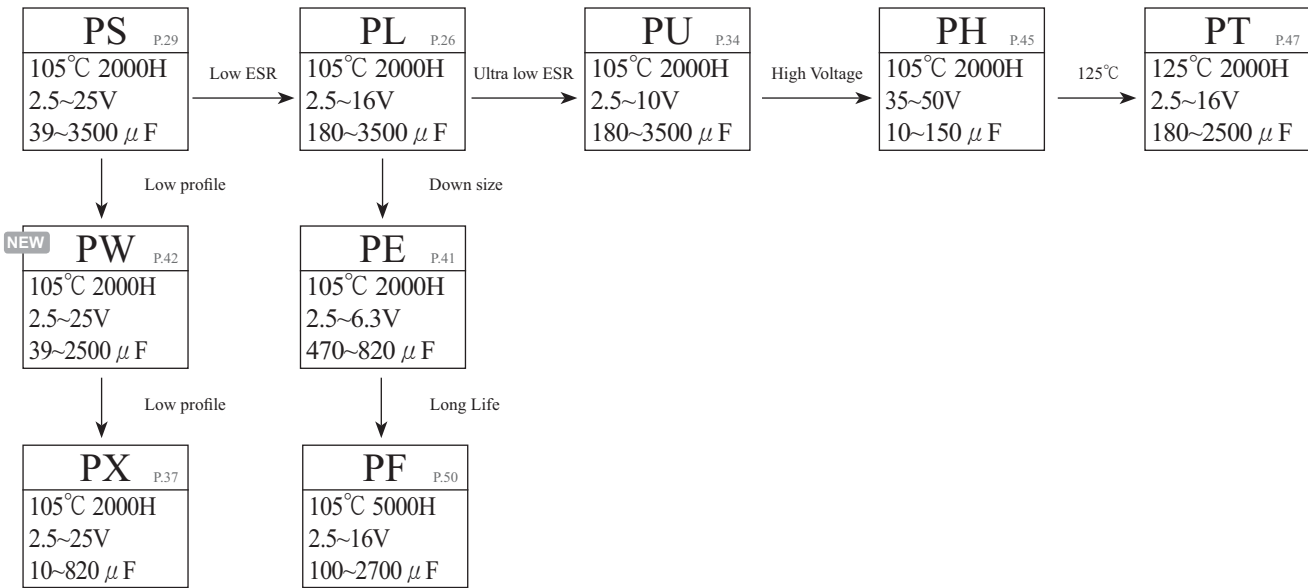

Conductive Polymer AL.E. Capacitors SMD type

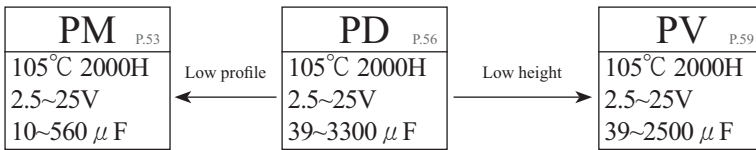

Aluminum Electrolytic Capacitors SMD type

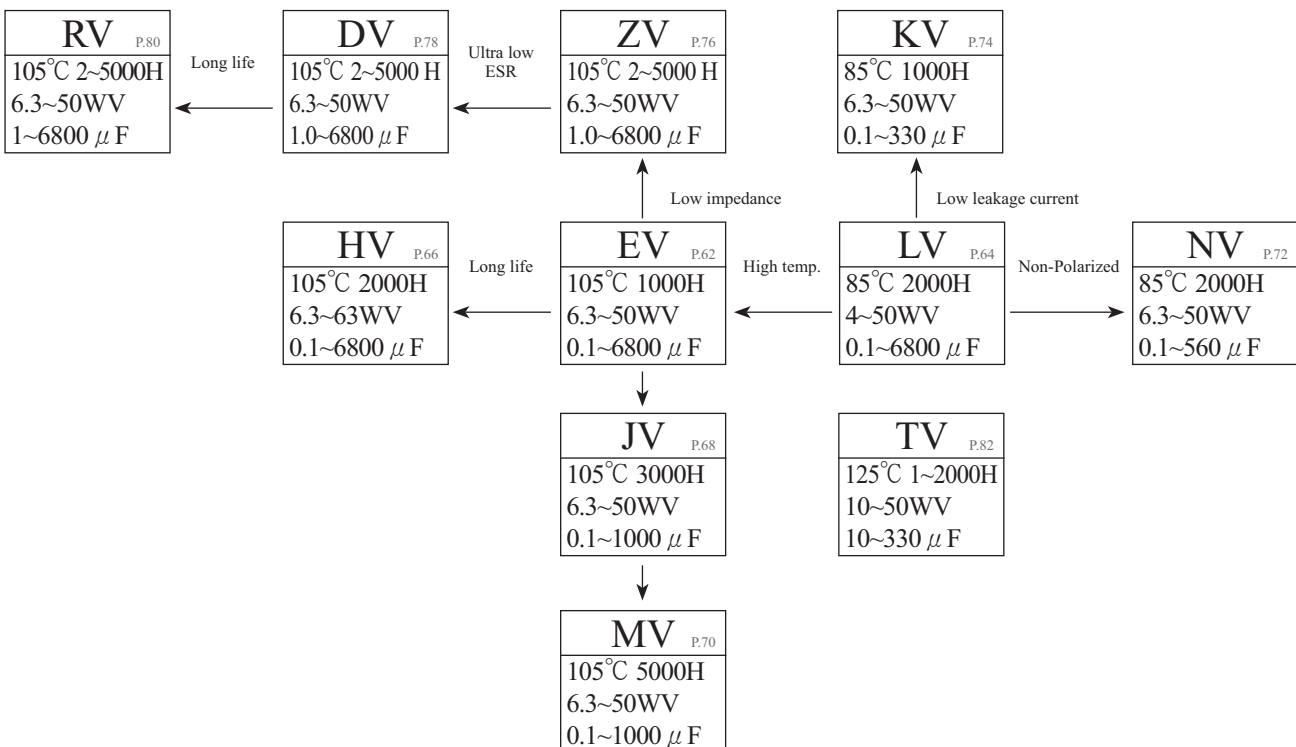

Radial type of aluminum Electrolytic Capacitors

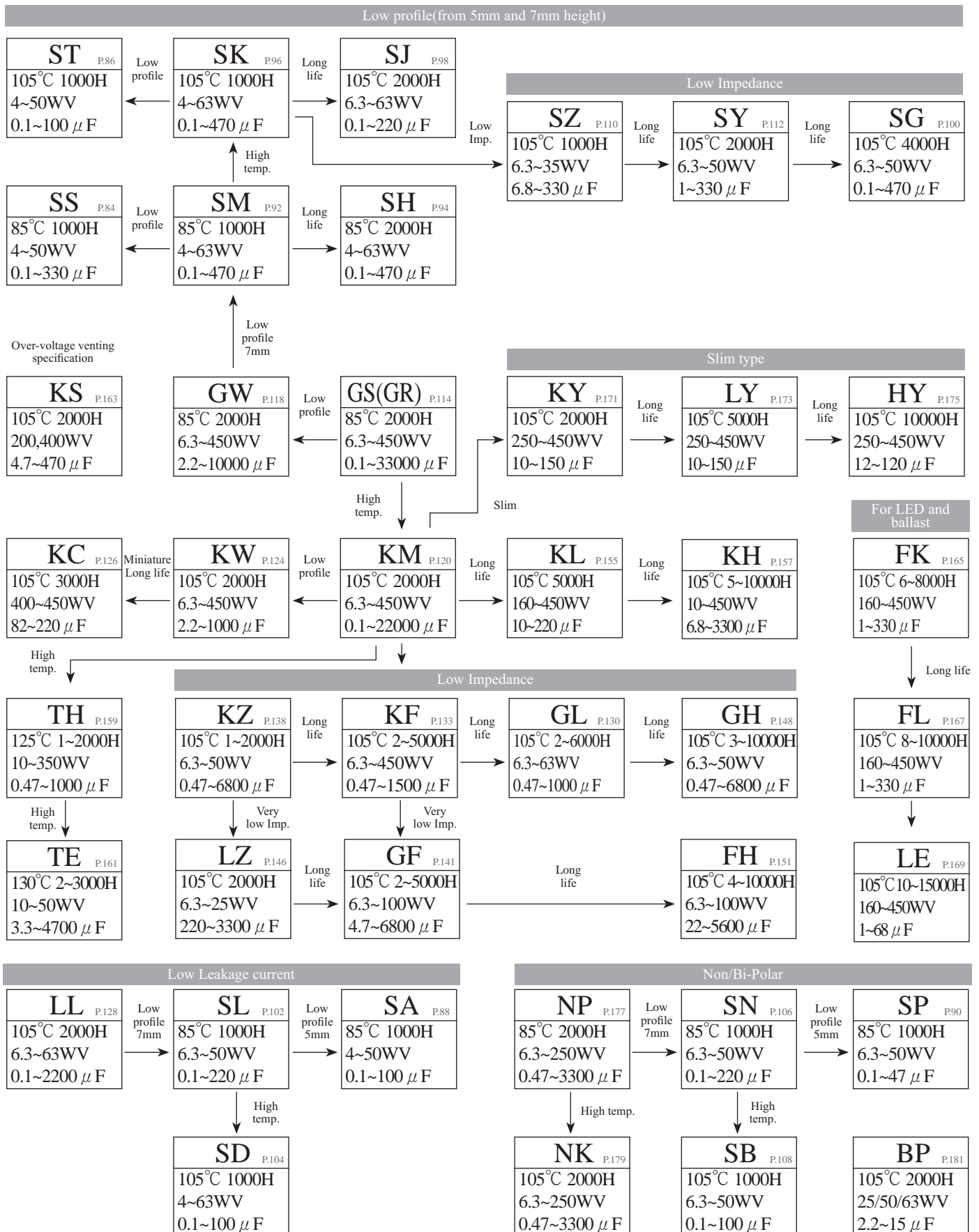

Aluminum Electrolytic Capacitors for audio equipment

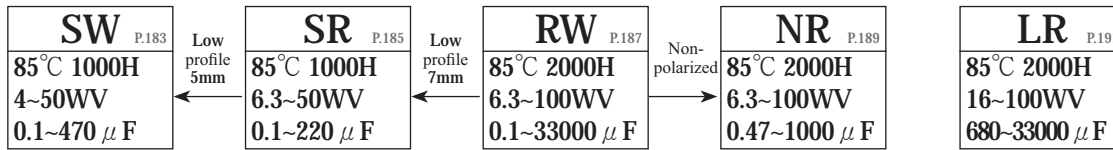

Snap-in type of aluminum Electrolytic Capacitors

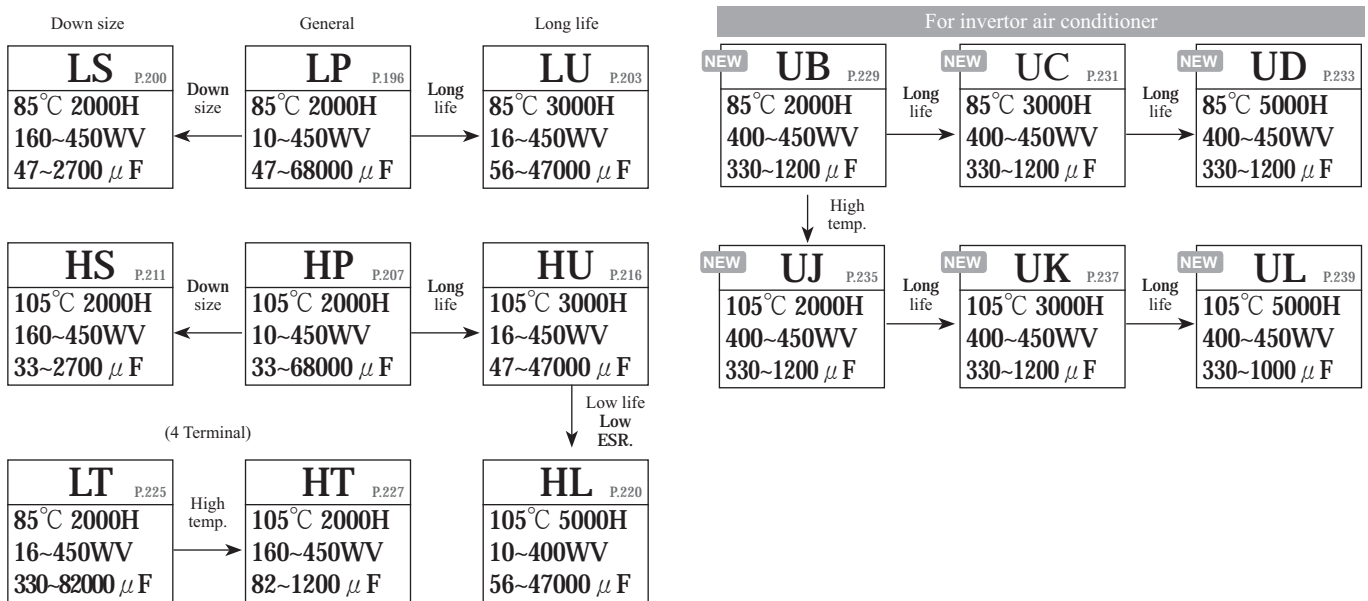
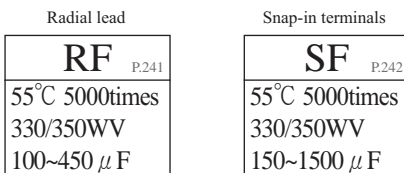
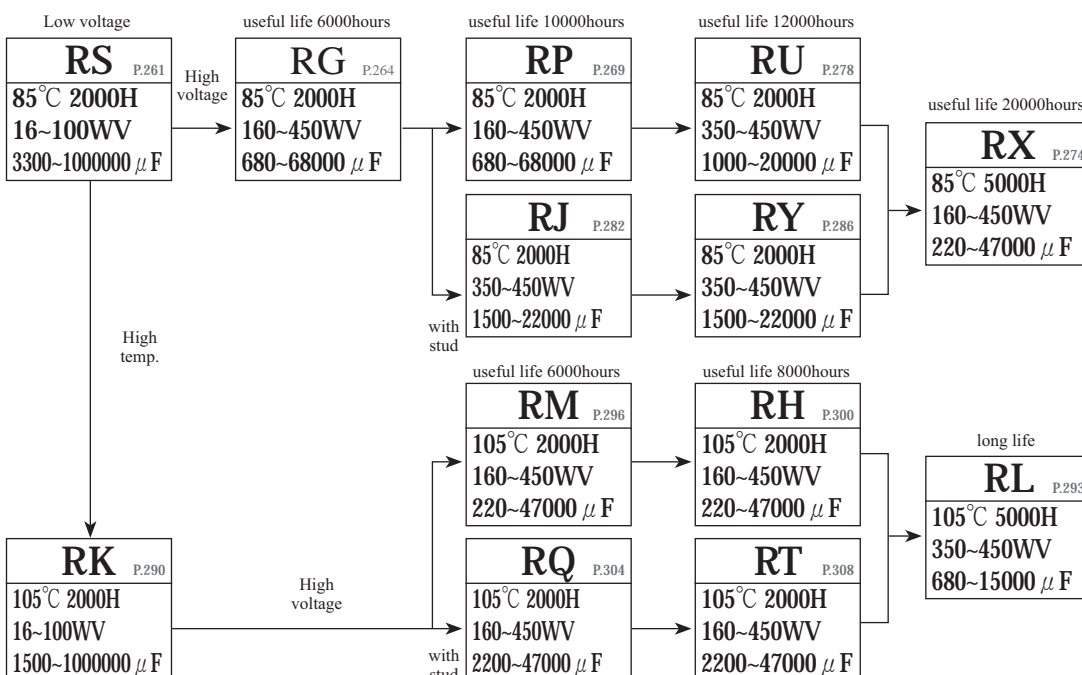
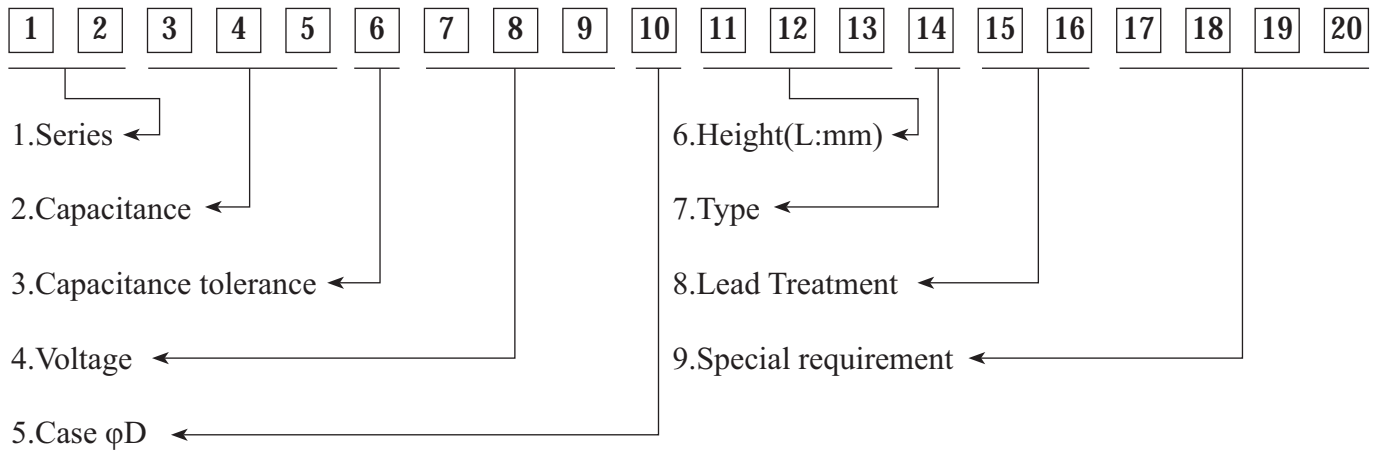

Photo flash type of aluminum Electrolytic Capacitors



Screw type of aluminum Electrolytic Capacitors





(1) Series

For the details, please refer to "List of the Products" on page3.

(2) Capacitance

Capacitance is shown in microfarads(uF)

μF	0.1	0.47	1	4.7	10	100	1000	10000
Code	oR1	R47	010	4R7	100	101	102	103

(3) Capacitance tolerance

Tolerance%	±5	±10	±20	±30	-10to+30	-10to+50	-10to+20	-10to100	0to+20	-30to+0	±15
Code	H	K	M	N	Q	T	V	W	Z	U	S
Tolerance%	0to+30	0to+40	0to+50	-5to+20	-8to+5	+5to+20	0to-20	-15to+20	-25to+20	-50to+0	-5to+30
Code	Y	X	A	J	E	I	B	P	L	O	C

(4) Voltage(W.V)

Voltage(W.V)	6.3	10	16	25	35	50	63	80	100	160	200	220	250	350	400	420	450	500
Code	6R3	010	016	025	035	050	063	080	100	160	200	220	250	350	400	420	450	500

(5) Case(φD)

Diameter	3	4	5	6.3	8	10	12	12.5	13	14.5	16	18	20	22	25	30	35	40	42	45	51	63.5	76.2	89	100
Code	A	B	C	E	F	G	H	Z	I	Y	J	K	L	M	N	O	P	Q	U	V	R	S	T	X	D

(6) Height(L:mm)

Height	5	7.5	11	11.5	12	12.5	16	21	25	26	25.5	31.5	35	35.5	41	47	52	83	98	118	141	151	230
Code	050	075	110	115	120	125	160	210	250	260	255	315	350	355	410	470	520	830	980	A18	A41	A51	B30

(7) Type

Type	Without Lead Treatment	With Lead Treatment	Polymer
Code	A	E	P

(8) Lead Treatment

For the details, please refer to page9-13.

(9) Special & appearance requirement (The 17th, 18th, 19th, 20th code)

Code	Special
A	Terminal
B	Rubber
C	Lead wire
D	DF
E	Electrolyte
F	Pitch
G	Fill glue
H	Height requirement

Code	Special
I	LC
K	Vent line
L	Life
N	Nude
P	Sleeve, tray, print, PVC sleeve
Q	Capacitance, Cv, Break
R	Ripple current
S	Countermeasure

Code	Special
T	Temperature characteristic
V	Vt, Electrolyte paper
M	solder, technics, form
Y	Case with snail, clip loop
Z	Impedance
U	Package& Label

Remark:

1. If it's without lead treatment & special requirement, the 14th code is blank
2. If it's with lead treatment & without require special requirement, the 17th 18th 19th 20th code is blank
3. If it's without lead treatment, but, with special requirement, the 15th 16th code filled with 0.
4. If it's without lead treatment, but with special requirement, also exceed 4 kinds, keystone characteristic is 4code.
5. If it's with lead treatment, but with 1 special requirement, only remark 17 code, latter three code is blank.
6. If it's with led treatment, but with 1 special requirement, and it is different from former data, the 17th is 0, the 18th code is characteristic.

Standard

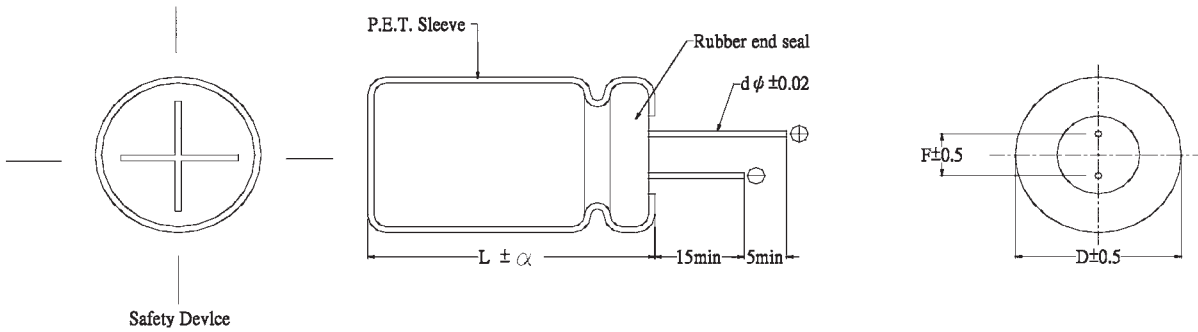

α	D < 18	D = 18		D > 18
	1.5	L < 35.5	L ≥ 35.5	2

Dφ	3	4	5	6.3	8		10	13	14.5	16	18	20	22	25
F	1.0	1.5	2.0	2.5	L < 20	L ≥ 20	5.0	7.5	10	12.5				
dφ	0.4	0.45	0.5		0.6		0.6	0.8			1.0			

Cutting & Forming

Part No. Code (15th, 16th)	Cutting & Forming	Size (mm)																						
CF	<p>Fig1</p>	<table border="1"> <tr> <td>Dφ</td> <td>4</td> <td>5</td> </tr> <tr> <td>F</td> <td>2</td> <td>2.5</td> </tr> </table>	Dφ	4	5	F	2	2.5																
	Dφ	4	5																					
F	2	2.5																						
	<p>Fig2</p>	<table border="1"> <tr> <td>Dφ</td> <td>4</td> <td>4</td> <td>4</td> <td>5</td> <td>5</td> <td>6.3</td> <td>6.3</td> <td>8</td> <td>10</td> <td>13</td> </tr> <tr> <td>F</td> <td>2.5</td> <td>3.5</td> <td>5</td> <td>3.5</td> <td>5</td> <td>3.5</td> <td>5</td> <td>5</td> <td>7.5</td> <td>7.5</td> </tr> </table>	Dφ	4	4	4	5	5	6.3	6.3	8	10	13	F	2.5	3.5	5	3.5	5	3.5	5	5	7.5	7.5
Dφ	4	4	4	5	5	6.3	6.3	8	10	13														
F	2.5	3.5	5	3.5	5	3.5	5	5	7.5	7.5														
KF	<p>Fig1</p>	<table border="1"> <tr> <td>Dφ</td> <td>4</td> <td>5</td> </tr> <tr> <td>F</td> <td>2</td> <td>2.5</td> </tr> <tr> <td>E</td> <td>1.12</td> <td>1.12</td> </tr> <tr> <td>H1</td> <td>4</td> <td>4</td> </tr> <tr> <td>H2</td> <td>1.8</td> <td>1.8</td> </tr> </table>	Dφ	4	5	F	2	2.5	E	1.12	1.12	H1	4	4	H2	1.8	1.8							
	Dφ	4	5																					
F	2	2.5																						
E	1.12	1.12																						
H1	4	4																						
H2	1.8	1.8																						
	<p>Fig2</p>	<table border="1"> <tr> <td>Dφ</td> <td>5</td> <td>6.3</td> <td>8</td> </tr> <tr> <td>F</td> <td>5</td> <td>5</td> <td>5</td> </tr> <tr> <td>E</td> <td>1.12</td> <td>1.12</td> <td>1.32</td> </tr> <tr> <td>H1</td> <td>4</td> <td>4</td> <td>4</td> </tr> <tr> <td>H2</td> <td>1.8</td> <td>1.8</td> <td>1.8</td> </tr> </table>	Dφ	5	6.3	8	F	5	5	5	E	1.12	1.12	1.32	H1	4	4	4	H2	1.8	1.8	1.8		
Dφ	5	6.3	8																					
F	5	5	5																					
E	1.12	1.12	1.32																					
H1	4	4	4																					
H2	1.8	1.8	1.8																					

Part No. Code (15th, 16th)	Cutting & Forming	Size (mm)																																													
CA		<table border="1"> <tr> <td>Dφ</td> <td>4</td> <td>5</td> <td>6.3</td> <td>8</td> <td>10</td> <td>13</td> <td>16</td> <td>18</td> <td>22</td> <td>25</td> </tr> <tr> <td>F</td> <td>1.5</td> <td>2</td> <td>2.5</td> <td>3.5</td> <td>5</td> <td>5</td> <td>7.5</td> <td>7.5</td> <td>10</td> <td>12.5</td> </tr> </table>	Dφ	4	5	6.3	8	10	13	16	18	22	25	F	1.5	2	2.5	3.5	5	5	7.5	7.5	10	12.5																							
Dφ	4	5	6.3	8	10	13	16	18	22	25																																					
F	1.5	2	2.5	3.5	5	5	7.5	7.5	10	12.5																																					
FA	<p>Fig1</p> <p>Fig2</p>	<table border="1"> <tr> <td>Dφ</td> <td>4</td> <td>5</td> </tr> <tr> <td>F</td> <td>2</td> <td>2.5</td> </tr> </table> <table border="1"> <tr> <td>Dφ</td> <td>4</td> <td>5</td> <td>6.3</td> <td>8</td> <td>10</td> <td>13</td> </tr> <tr> <td>F</td> <td>5</td> <td>5</td> <td>5</td> <td>5</td> <td>7.5</td> <td>7.5</td> </tr> </table>	Dφ	4	5	F	2	2.5	Dφ	4	5	6.3	8	10	13	F	5	5	5	5	7.5	7.5																									
Dφ	4	5																																													
F	2	2.5																																													
Dφ	4	5	6.3	8	10	13																																									
F	5	5	5	5	7.5	7.5																																									
CK		<table border="1"> <tr> <td>Dφ</td> <td>4</td> <td>5</td> <td>6.3</td> <td>8</td> <td>10</td> <td>13</td> <td>16</td> <td>18</td> </tr> <tr> <td>F</td> <td>1.5</td> <td>2</td> <td>2.5</td> <td>3.5</td> <td>5</td> <td>5</td> <td>7.5</td> <td>7.5</td> </tr> <tr> <td>C</td> <td>4</td> <td>4</td> <td>4</td> <td>4</td> <td>4.5</td> <td>4.5</td> <td>4.5</td> <td>4.5</td> </tr> <tr> <td>K</td> <td>4</td> <td>4</td> <td>4</td> <td>4</td> <td>4.5</td> <td>4.5</td> <td>4.5</td> <td>4.5</td> </tr> </table>	Dφ	4	5	6.3	8	10	13	16	18	F	1.5	2	2.5	3.5	5	5	7.5	7.5	C	4	4	4	4	4.5	4.5	4.5	4.5	K	4	4	4	4	4.5	4.5	4.5	4.5									
Dφ	4	5	6.3	8	10	13	16	18																																							
F	1.5	2	2.5	3.5	5	5	7.5	7.5																																							
C	4	4	4	4	4.5	4.5	4.5	4.5																																							
K	4	4	4	4	4.5	4.5	4.5	4.5																																							
KA	<p>Fig1</p>	<table border="1"> <tr> <td>Dφ</td> <td>5</td> <td>6.3</td> <td>8</td> <td>10</td> <td>13</td> <td>16</td> <td>18</td> <td>22</td> </tr> <tr> <td>F</td> <td>2</td> <td>2.5</td> <td>3.5</td> <td>5</td> <td>5</td> <td>7.5</td> <td>7.5</td> <td>10</td> </tr> <tr> <td>E</td> <td>1.12</td> <td>1.12</td> <td>1.32</td> <td>1.32</td> <td>1.32</td> <td>1.32</td> <td>1.32</td> <td>1.82</td> </tr> <tr> <td>H1</td> <td>4</td> <td>4</td> <td>4</td> <td>4.5</td> <td>4.5</td> <td>4.5</td> <td>4.5</td> <td>4.5</td> </tr> <tr> <td>H2</td> <td>1.8</td> <td>1.8</td> <td>1.8</td> <td>1.8</td> <td>1.8</td> <td>1.8</td> <td>1.8</td> <td>1.8</td> </tr> </table>	Dφ	5	6.3	8	10	13	16	18	22	F	2	2.5	3.5	5	5	7.5	7.5	10	E	1.12	1.12	1.32	1.32	1.32	1.32	1.32	1.82	H1	4	4	4	4.5	4.5	4.5	4.5	4.5	H2	1.8	1.8	1.8	1.8	1.8	1.8	1.8	1.8
Dφ	5	6.3	8	10	13	16	18	22																																							
F	2	2.5	3.5	5	5	7.5	7.5	10																																							
E	1.12	1.12	1.32	1.32	1.32	1.32	1.32	1.82																																							
H1	4	4	4	4.5	4.5	4.5	4.5	4.5																																							
H2	1.8	1.8	1.8	1.8	1.8	1.8	1.8	1.8																																							

Part No. Code (15th, 16th)	Cutting & Forming	Size (mm)																																	
EF		<table border="1"> <tr><td>Dφ</td><td>4</td><td>5</td><td>6.3</td><td>8</td></tr> <tr><td>F</td><td>5</td><td>5</td><td>5</td><td>5</td></tr> <tr><td>F1</td><td>1.2</td><td>1.2</td><td>1.2</td><td>1.2</td></tr> <tr><td>H1</td><td>4</td><td>4</td><td>4</td><td>4</td></tr> <tr><td>H2</td><td>1.8</td><td>1.8</td><td>1.8</td><td>1.8</td></tr> </table>	Dφ	4	5	6.3	8	F	5	5	5	5	F1	1.2	1.2	1.2	1.2	H1	4	4	4	4	H2	1.8	1.8	1.8	1.8								
Dφ	4	5	6.3	8																															
F	5	5	5	5																															
F1	1.2	1.2	1.2	1.2																															
H1	4	4	4	4																															
H2	1.8	1.8	1.8	1.8																															
CR		<table border="1"> <tr><td>Dφ</td><td>4</td><td>5</td><td>6.3</td><td>8</td><td>10</td><td>13</td><td>16</td><td>18</td><td>22</td><td>25</td></tr> <tr><td>F</td><td>1.5</td><td>2</td><td>2.5</td><td>3.8</td><td>5</td><td>5</td><td>7.5</td><td>7.5</td><td>10</td><td>12.5</td></tr> <tr><td>H1</td><td>2.5</td><td>2.5</td><td>2.5</td><td>2.5</td><td>2.5</td><td>2.5</td><td>2.5</td><td>2.5</td><td>2.5</td><td>2.5</td></tr> </table>	Dφ	4	5	6.3	8	10	13	16	18	22	25	F	1.5	2	2.5	3.8	5	5	7.5	7.5	10	12.5	H1	2.5	2.5	2.5	2.5	2.5	2.5	2.5	2.5	2.5	2.5
Dφ	4	5	6.3	8	10	13	16	18	22	25																									
F	1.5	2	2.5	3.8	5	5	7.5	7.5	10	12.5																									
H1	2.5	2.5	2.5	2.5	2.5	2.5	2.5	2.5	2.5	2.5																									
CL		<table border="1"> <tr><td>Dφ</td><td>4</td><td>5</td><td>6.3</td><td>8</td><td>10</td><td>13</td><td>16</td><td>18</td><td>22</td><td>25</td></tr> <tr><td>F</td><td>1.5</td><td>2</td><td>2.5</td><td>3.8</td><td>5</td><td>5</td><td>7.5</td><td>7.5</td><td>10</td><td>12.5</td></tr> <tr><td>H1</td><td>2.5</td><td>2.5</td><td>2.5</td><td>2.5</td><td>2.5</td><td>2.5</td><td>2.5</td><td>2.5</td><td>2.5</td><td>2.5</td></tr> </table>	Dφ	4	5	6.3	8	10	13	16	18	22	25	F	1.5	2	2.5	3.8	5	5	7.5	7.5	10	12.5	H1	2.5	2.5	2.5	2.5	2.5	2.5	2.5	2.5	2.5	2.5
Dφ	4	5	6.3	8	10	13	16	18	22	25																									
F	1.5	2	2.5	3.8	5	5	7.5	7.5	10	12.5																									
H1	2.5	2.5	2.5	2.5	2.5	2.5	2.5	2.5	2.5	2.5																									
CS		<table border="1"> <tr><td>Dφ</td><td>4</td><td>5</td><td>6.3</td><td>8</td><td>10</td><td>13</td><td>16</td><td>18</td><td>22</td><td>25</td></tr> <tr><td>F</td><td>1.5</td><td>2</td><td>2.5</td><td>3.8</td><td>5</td><td>5</td><td>7.5</td><td>7.5</td><td>10</td><td>12.5</td></tr> </table>	Dφ	4	5	6.3	8	10	13	16	18	22	25	F	1.5	2	2.5	3.8	5	5	7.5	7.5	10	12.5											
Dφ	4	5	6.3	8	10	13	16	18	22	25																									
F	1.5	2	2.5	3.8	5	5	7.5	7.5	10	12.5																									
CZ		<table border="1"> <tr><td>Dφ</td><td>4</td><td>5</td><td>6.3</td><td>8</td><td>10</td><td>13</td><td>16</td><td>18</td><td>22</td><td>25</td></tr> <tr><td>F</td><td>1.5</td><td>2</td><td>2.5</td><td>3.8</td><td>5</td><td>5</td><td>7.5</td><td>7.5</td><td>10</td><td>12.5</td></tr> </table>	Dφ	4	5	6.3	8	10	13	16	18	22	25	F	1.5	2	2.5	3.8	5	5	7.5	7.5	10	12.5											
Dφ	4	5	6.3	8	10	13	16	18	22	25																									
F	1.5	2	2.5	3.8	5	5	7.5	7.5	10	12.5																									

Radial

Taping

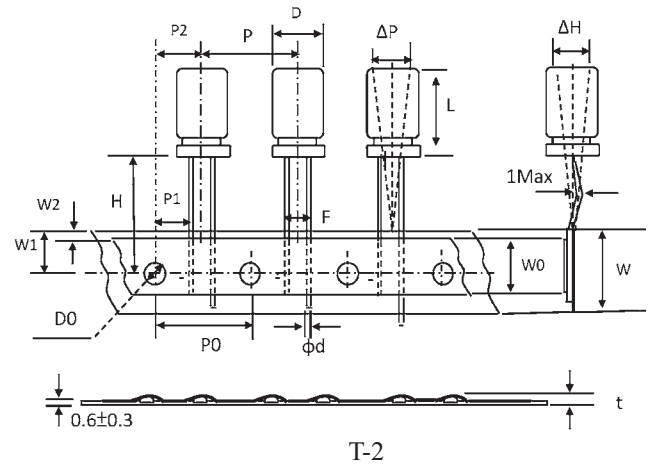
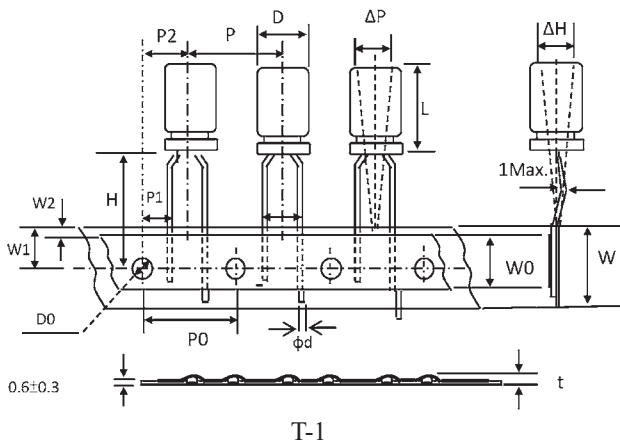

Specification Information

Code	D	L	d	P	P0	P1	P2	F	W	W0	W1	W2	H	D0	Δh	T1	t	code	Fig
Tol.	±0.5	Max	±0.02	±1.0	±0.2	±0.7	±1.3	0.4 -0.2	±0.5	±0.5	±0.5	Max	0.75 -0.5	±0.2	Max	±0.3	Max		
Item	4	5-7(+1)	0.45	12.7	12.7	5.35	6.35	2	18	11	9	2	18.5	4.0	1	0.6	1.5	TB	T-1
			0.5			5.1		2.5										TC	
Item	5	5-7(+1) 9-15(±1.5)	0.45	12.7	12.7	4.6	6.35	2.5	18	11	9	2	18.5	4.0	1	0.6	1.5	TC	
			0.5																

Code	D	L	d	P	P0	P1	P2	F	W	W0	W1	W2	H	D0	Δh	ΔP	t	code	Fig
Tol.	±0.5	Max	±0.02	±1.0	±0.2	±0.7	±1.3	0.4 -0.2	±0.5	±0.5	±0.5	Max	0.75 -0.5	±0.2	Max	Max	Max		
Item	5	5-7(+1)	0.45	12.7	12.7	5.35	6.35	2.0	18	11	9	2.0	18.5	4.0	1	-	1.5	TB	T-2
		9-15(±1.5)	0.5																
	6.3	5(+1)	0.45	12.7	12.7	5.1	6.35	2.5	18	11	9	2.0	18.5	4.0	1	-	1.5	TC	
		7(+1)	0.5																
10(+1)*		0.6																	
Item	8	9-15(±1.5)	0.5	12.7	12.7	4.6	6.35	3.5	18	11	9	2.0	18.5	4.0	1	-	1.5	TD	
		5-7(+1)	0.5																
		8(+1)*	0.6																
		11.5(+1.5)*	0.6																
Item	10	9-30(±1.5)	0.6	12.7	12.7	3.85	6.35	5.0	18	11	9	2.0	18.5	4.0	1	-	1.5	TA	
Item	13	13-40(±1.5)	0.6	15	15	5	7.5	5.0	18	15	9	2.0	18.5	4.0	2	-	1.5	TA	

* : In this case, that is suitable for polymer.

Taping

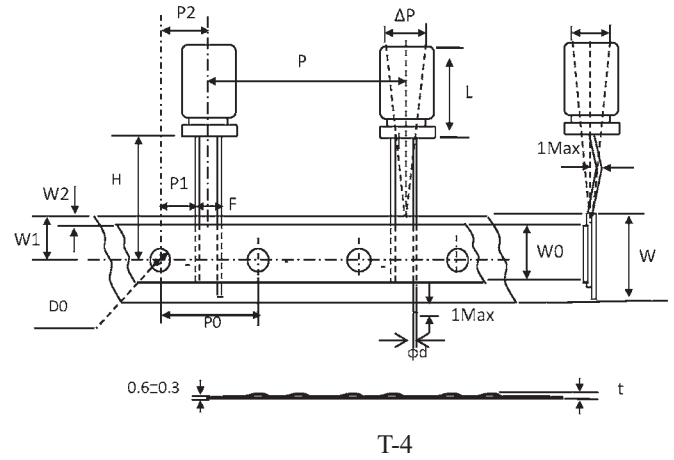
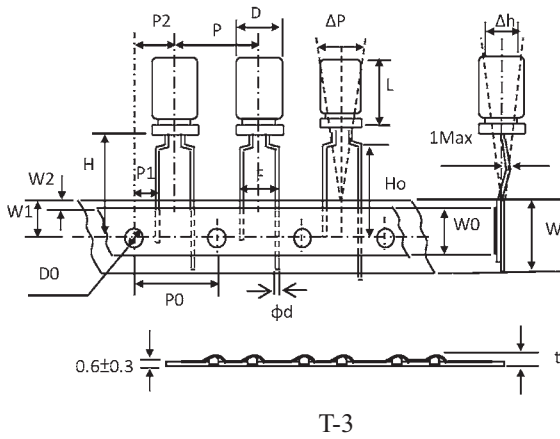

Specification Information

Code	D	L	d	P	P0	P1	P2	F	W	W0	W1	W2	H	H0	D0	Δh	ΔP	t	code	Fig
Tol.	±0.5	Max	±0.02	±1.0	±0.2	±0.3	±1.0	0.4 -0.2	±0.5	±0.5	±0.5	Max	0.75 -0.5	±0.5	±0.2	Max	Max	Max		
Item	4	5-7(+1)	0.45	12.7	12.7	3.85	6.35	5	18	11	9	2.0	18.5	16	4.0	1	1	1.5	TA	T-3
	5	5-7(+1)	0.45	12.7	12.7	3.85	6.35	5	18	11	9	2.0	18.5	16	4.0	1	1	1.5		
		9-15(±1.5)	0.5																	
	6.3	5(+1)	0.45	12.7	12.7	3.85	6.35	5	18	11	9	2.0	18.5	16	4.0	1	1	1.5		
		7(+1)	0.5																	
		10(+1)*	0.6																	
		9-15(±1.5)	0.5																	
8	5-8(+1)	0.5	12.7	12.7	3.85	6.35	5	18	11	9	2.0	18.5	16	4.0	1	1	1.5			
	9-20(±1.5)	0.5																		

Code	D	L	d	P	P0	P1	P2	F	W	W0	W1	W2	H	D0	Δh	l	t	code	Fig
Item	±0.5	±1.5	±0.02	±1.0	±0.2	±0.7	±1.3	0.4 -0.2	±0.5	±0.5	±0.5	Max	+0.75 -0.5	±0.2	Max	Min	Max	TA	T-4
	13	13~40(±1.5)	0.6	25.4	12.7	3.85	6.35	5	18	15	9	2.0	18.5	4.0	2	1	1.5		
	16	16~40(±1.5)	0.8	30	15	3.75	7.5	7.5	18	15	9	2.0	18.5	4.0	2	1	1.5		

* : In this case, that is suitable for polymer.

Part Number Ammo Package

F	5	2	2.5	3.5	7.5	SMD
Code (15th, 16th)	TA	TB	TC	TD	TE	TR

Part Number Reel Package

F	5	2	2.5	3.5	7.5
Code (15th, 16th)	RA	RB	RC	RD	RE

Package Information

Size $\phi D \times L$ (mm)	Ammo Package		
	W	A	Quantity (pcs)
4 x all	227	51	2500
5 x all	227	51	2000
6.3 x all	227	51	1500
8 x 5~16	227	51	800
8 x 17~25	191	57	800
10 x 7~15	227	51	600
10 x 16~20	191	57	500
10 x 21~25	190	60	500
13 x 13~15	227	51	300
13 x 16~20	191	57	300
13 x 21~25	190	60	300
13 x 26~30	216	64	300
16 x 16~20	191	57	200
16 x 21~25	216	64	200
16 x 26~30	254	67	250
16 x 31~35.5	230	71	250

Size $\phi D \times L$ (mm)	Reel Package	
	AW	Quantity (pcs)
4 x all	45	1800
5 x all	45	1300
6.3 x all	45	1000
8 x 5~17	45	800
8 x 18~28	55	800
10 x 7~17	45	600
10 x 18~28	55	600
13 x 13~17	45	300
13 x 18~28	55	300
16 x 13~17	45	200
16 x 18~28	55	200

Ammo Package

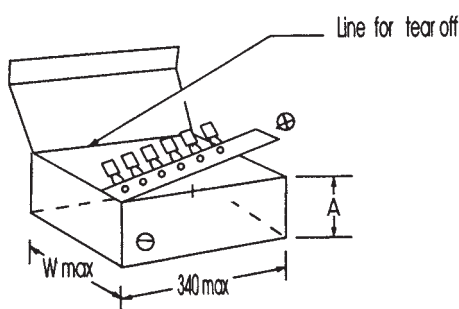

Reel Package

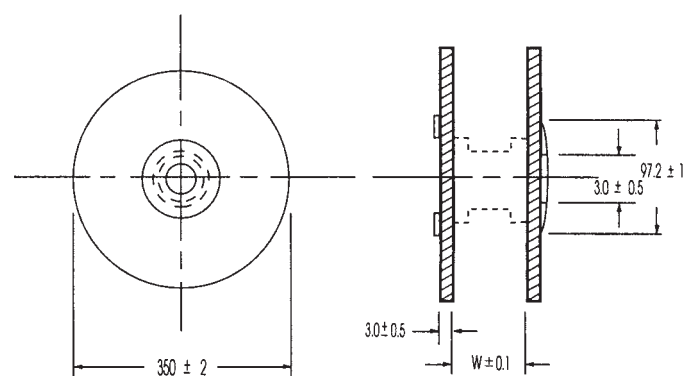

Available terminal for Snap-in Type

Please consult us about terminal type other those blow listed.

1. Standard terminal type

Terminal code:PP

D=Φ22 to Φ40

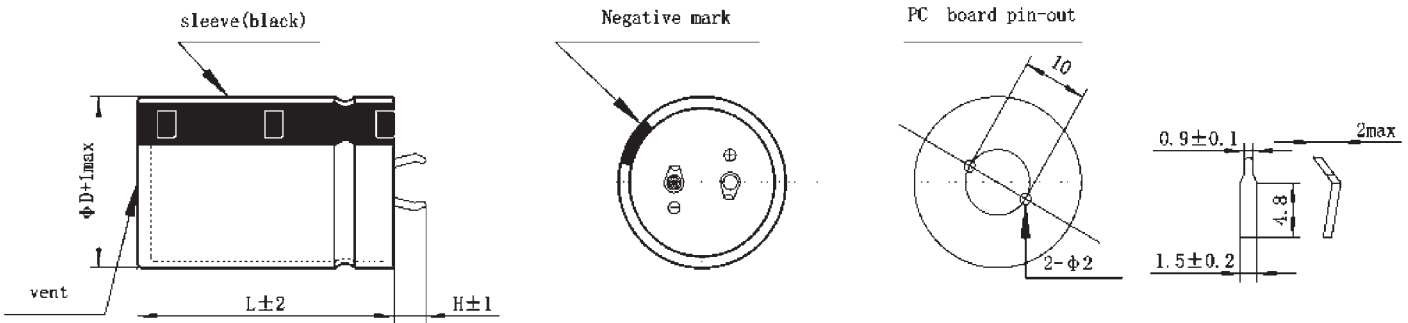

Standard snap-in terminals:Length 6.0±1mm.Also available with length of 4.0±1mm

2. Vibration proof terminal T type

Terminal code:CP

D=Φ30 to Φ40

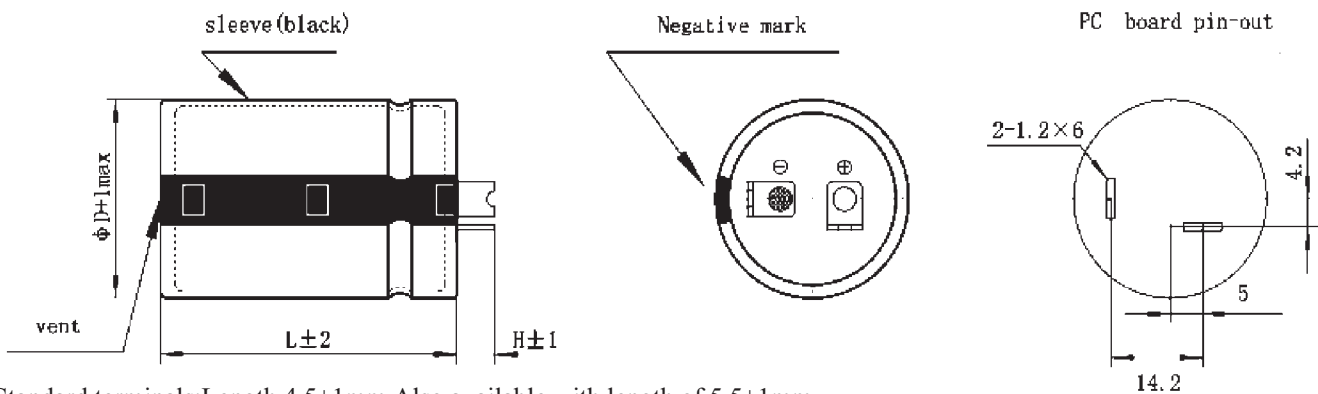

Standard terminals:Length 4.5±1mm.Also available with length of 5.5±1mm

3. Soldering Type terminal

Terminal code:VP

D=Φ30 to Φ40

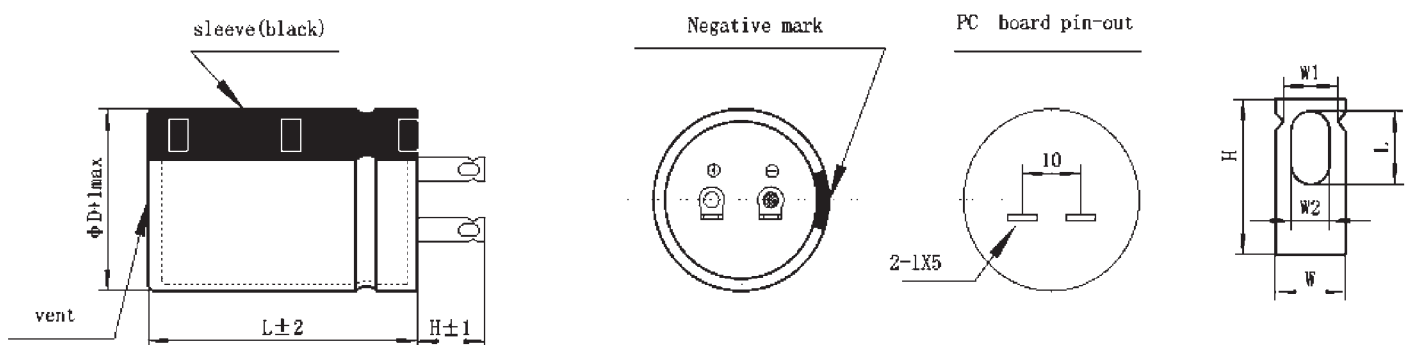

Standard terminals:Length 6±1mm.Also available with length of 5.0±1mm or 12.0±1mm

4. Vibration proof terminal U type

Terminal code:HP

D=Φ30 to Φ40

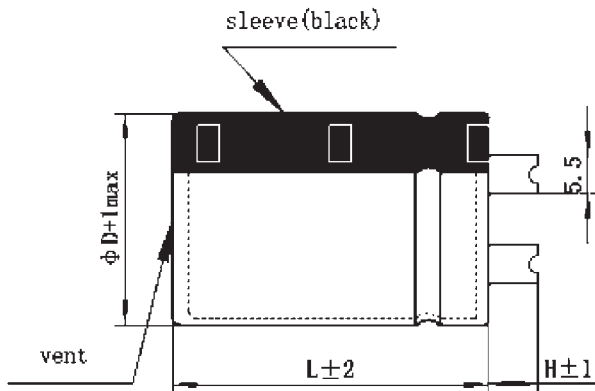

Negative mark

PC board pin-out

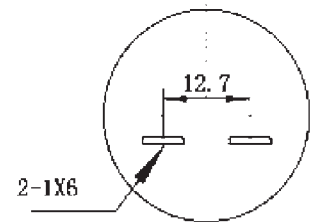
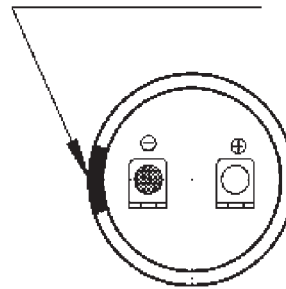

Standard terminals: Length $6 \pm 1 \text{ mm}$.

5. Long terminal for Left or right bending type

Terminal code:HP

D=Φ30 to Φ40

Left bending(C+L):

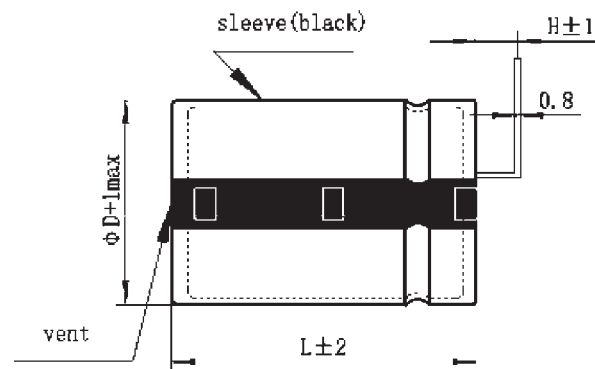

Negative mark

PC board pin-out

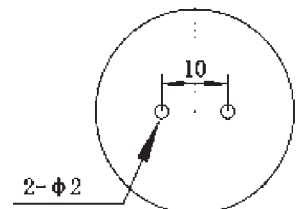
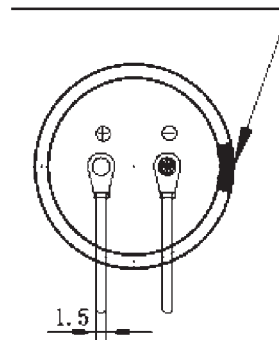

Right bending(C+R):

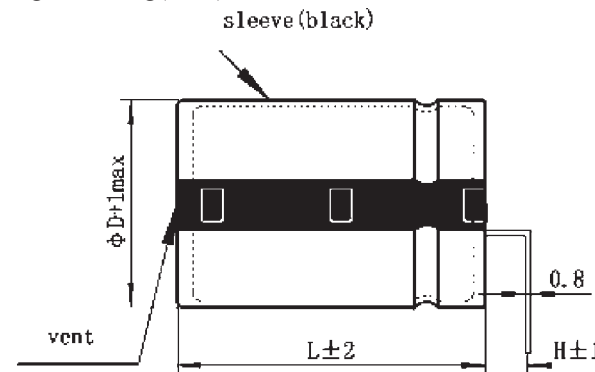

Negative mark

PC board pin-out

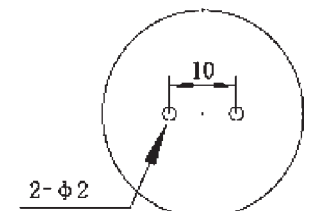
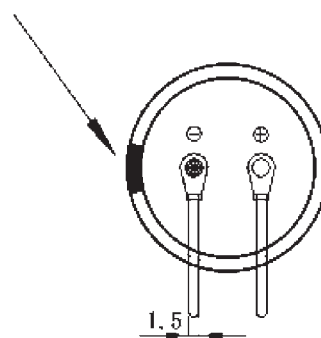

Standard terminals: H Length $2.5 \pm 1 \text{ mm}$.

6. Slim terminal type

Terminal code:LP

D=Φ22 to Φ40

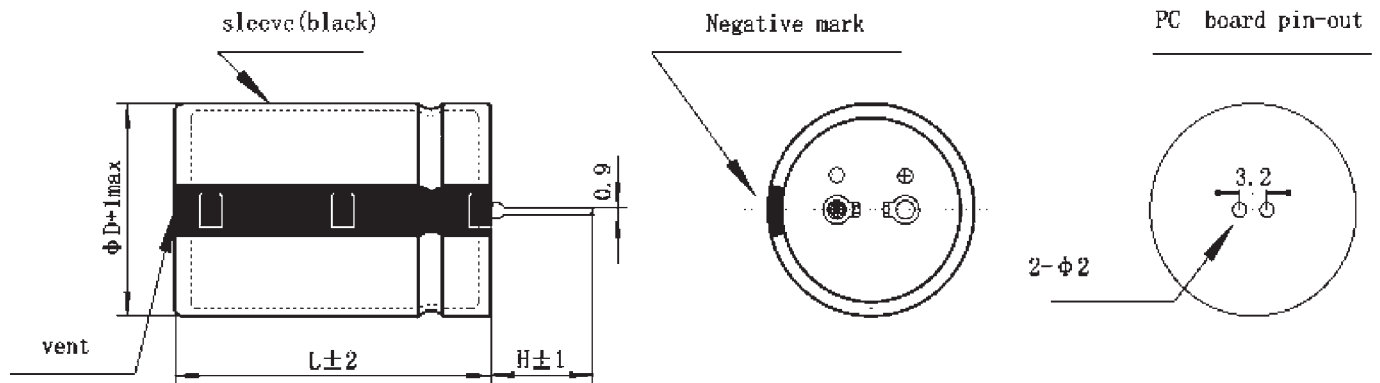

Standard terminals:Length 9.5±1mm. Also available with length of 4.0±1mm.

7. 3pin snap-in terminal type

Terminal code:ZP

D=Φ22 to Φ40

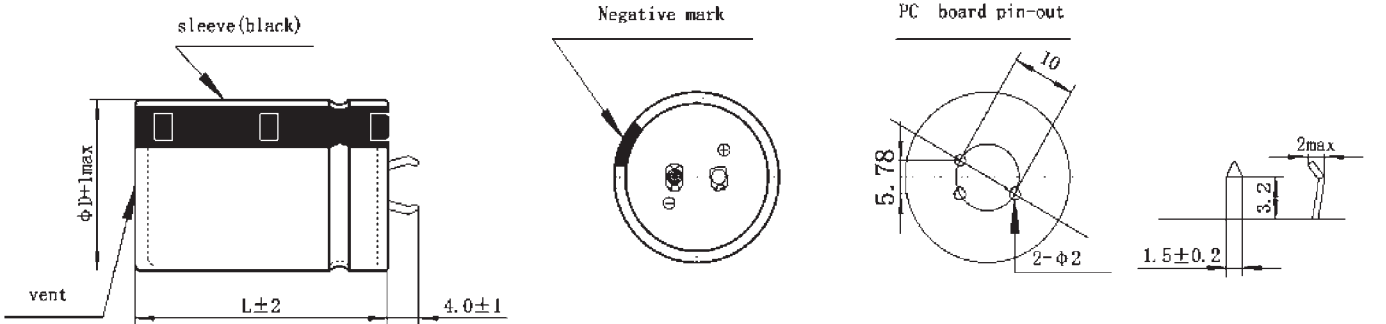

8. 4pin snap-in terminal type

Terminal code:YP

D=Φ30 to Φ40

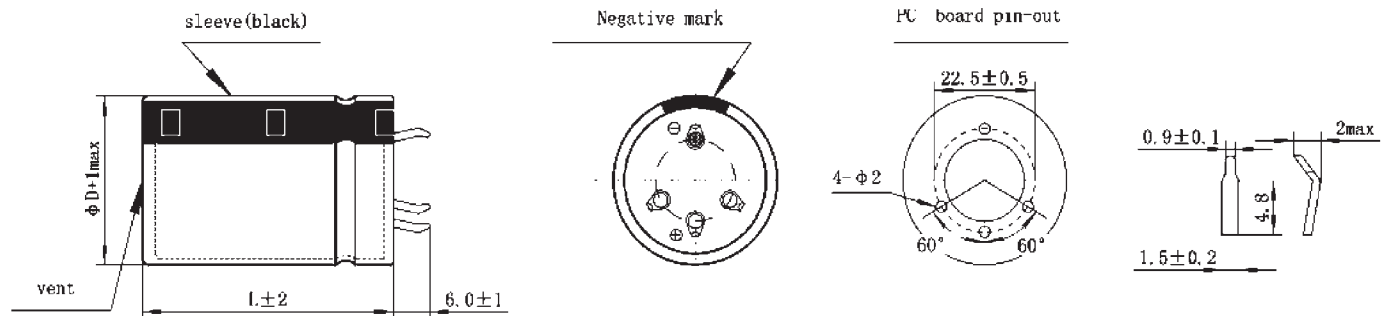

Package for Snap-in type

Packing

Capacitor diameter D(mm)	Length L(mm)	Terminal length H(mm)	Each carton packing Qty units(pcs.)	Box/carton units(pcs.)	Each box packing Qty units(pcs.)
20	all	/	720	6	120
22	all	/	600	6	100
25	all	/	500	5	100
30	≤36	<6	400	8	50
30	≥36	≥6	300	6	50
35	<27	/	400	8	50
35	27≤L≤42	/	300	6	50
35	>42	/	200	4	50
40	<37	/	200	5	40
40	37≤L<47	/	160	4	40
40	≥47	/	120	3	40

Packing of Snap-in



Carrier tape

4φ~10φ:

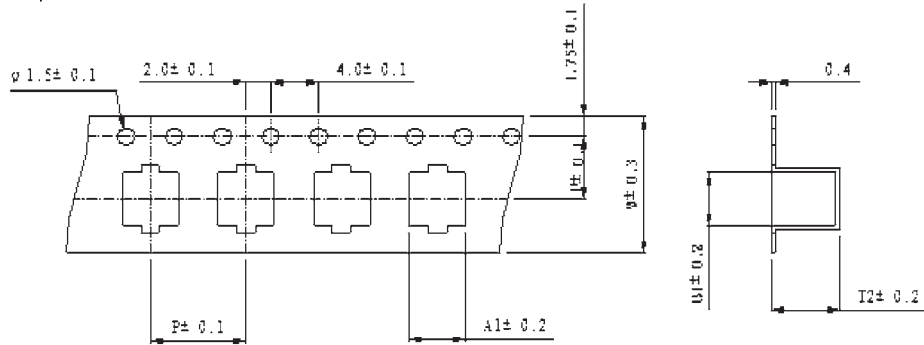

12.5φ~16φ:

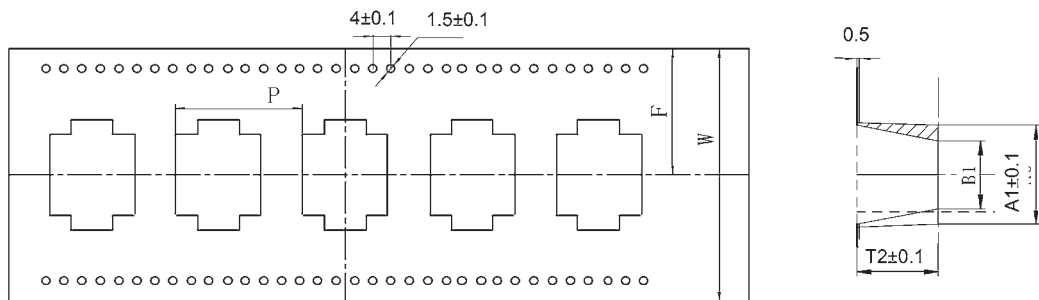

Unit: mm

φD	4x5.5	5x5.5	6.3x6.1	6.3x5.5	6.3x5.8	6.3x7.7	8x6.5	8x7.7	8x10.5	8x11.7	10x8.7	10x10.5	10x12.4	12.5X14	16X17
W	12.0	12.0	16	16.0	16.0	16.0	16	16	24.0	24.0	24	24.0	24.0	32	44
P	8.0	12.0	12	12.0	12.0	12.0	12	12	16.0	16.0	16	16.0	16.0	24	28
F	5.5	5.5	9.25	7.5	7.5	7.5	7.5	7.5	11.5	11.5	11.5	11.5	11.5	16	21.95
A ₁	4.7	5.7	7	7.0	7.0	7.0	8.7	8.7	8.7	8.7	10.7	10.7	10.7	13.9	19.5
B ₁	4.7	5.7	7	7.0	7.0	7.0	8.7	8.7	8.7	8.7	10.7	10.7	10.7	13.9	17.5
T ₂	5.7	5.7	6.2	5.7	5.7	8.0	7.0	8.2	11.0	11.0	8.2	11.0	12.9	14.5	17.3

Reel

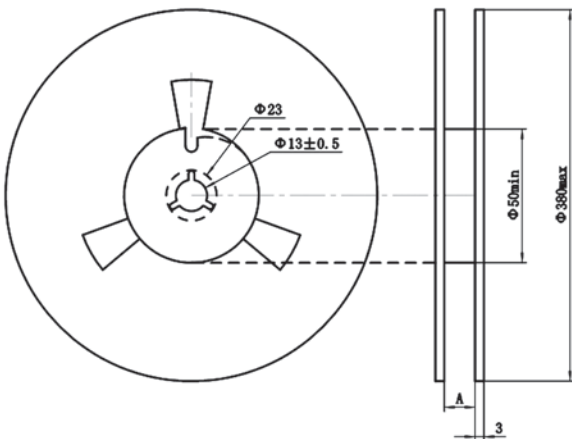

Dφ	4	5	6.3, 8	8, 10	12.5	16
A	14	14	18	26	34	46

φD	Quantity
4X5.5	2000pcs
5x5.5	1000pcs
6.3x6.1	1000pcs
6.3x5.5	1000pcs
6.3x5.8	1000pcs
6.3x7.7	900 pcs
8x6.5	1000pcs
8x7.7	700pcs
8x10.5	500pcs
8x11.7	400pcs
10x8.7	700pcs
10x10.5	500pcs
10x12.4	400pcs
12.5X14	200pcs
16X17	125pcs

For Conductive Polymer Capacitors

CP-CAP is a solid aluminum capacitor with conductive polymer electrolyte. Please read the following points in order to take the most out of your CP-CAP.

Designing device circuits

1. Circuits where CP-CAPs are prohibited to used

The leakage current of conductive polymer solid aluminum capacitors may vary depending on thermal stresses. Please don't use solid capacitors in the following types of circuits:

- (1) High-impedance circuits that are to sustain voltages.
- (2) Coupling circuits
- (3) Time constant circuits

In addition to the leakage current fluctuation, capacitance may also fluctuate depending on operational temperature and humidity. The fluctuation of the capacitance may cause problem if it is used as a time constant capacitor, which is extremely sensitive to the fluctuation of the capacitance. Do not use it as a time constant capacitance.

- (4) Other circuits that are significantly affected by leakage current. If you want to use 2 or more CP-CAPs in a series connection, please contact us before use.

2. Polarity

The CP-CAP is a polarized solid aluminum electrolytic capacitor. Do not apply either reverse voltages or AC voltages to the polarized capacitors, using reverse polarity may cause a short circuit. Refer to the catalog, product specifications or capacitor body to confirm the polarity prior to use.

3. Applied voltage

Do not apply DC voltages exceeding the full rated voltage. The peak voltage of superimposed AC voltages (ripple voltages) on DC voltages must not exceed the full rated voltage. While there are specifications for surge voltages exceeding the rated voltage, usage conditions apply, and continued operation for extended periods of time under such conditions cannot be guaranteed. Use the within 20% of the rated voltage for applications which may cause the reverse voltage during the transient phenomena when the power is turned off or the source is switched.

4. Ripple current

Do not apply currents in excess of the rated ripple current. The superimposition of a large ripple current increases the rate of heating within the capacitor. This may reduce the service life of the capacitor or damage the capacitor.

5. Operating temperature

Do not use the CP-CAP at high temperatures (temperatures exceeding the maximum temperature for the capacitor category) Use of the capacitor outside of the maximum temperature for the capacitor category may decrease the service life of the capacitor.

6. Sudden charge and discharge

Do not use the CP-CAP in circuits where the capacitor is repetitively charged and discharged rapidly. Repetitively charging and discharging the capacitor rapidly may reduce the capacitance or may cause damage due to internal heating. Use of a protective circuit to ensure reliability is recommended when rush currents exceed 10A or the rush current is over 10 times of allowable ripple current of CP-CAP.

A protection resistor(1 k Ω) must be inserted to the circuit during the charge and discharge when measuring the leakage current.

7. Failures and life-span

The CP-CAP failure rate in use is based on the failure rate level in the specification requirements. Upper category temperature and category voltage adhere to JIS C 5003 Standard. The confidence level is 60% and the failure rate is 0.5%/1,000 hours (applied rated voltage at category temperature).

The failure modes mainly have 2 types as follows.

(1) Contingency failure

The contingency failure mainly has short circuit. The phenomenon of after short is on following.

- (i) In the event a short circuit causes the current to become relatively small(less than approximately 1A for ϕ 10, less than approximately 0.5A for ϕ 8 and less than approximately 0.2A for smaller than ϕ 6.3),the CP-CAP itself will generate a little heat, but its appearance will not be affected even when electricity is supplied continuously. However, if the short circuit current value exceeds the mentioned values above, the temperature inside the CP-CAP will increase, the internal pressure is

raised, rubber sealing is turned over, and odorous gas is released. In this case, keep your face and hands away from the area.

- (ii) The electrolyte, electrolytic paper, sealing rubber, and plastic spacer used in the CP-CAP are all combustible. If an extremely large electric current flows through the capacitor after shorting, the shorted part may spark, and in a worst case scenario, may ignite. Ensure safety by fully considering the design issues described below when using this capacitor in equipment where safety is a priority.

- Increase safety by using in conjunction with a protective circuit or protective equipment.
- Install measures such as redundant circuits so that the failure of a part of the equipment will not cause unstable operation.

(2) Performance characteristic and failure(life-span)

CP-CAP characteristics can possibly change(capacitance reduction and ESR increase) within the specified range in specifications when it is used in the condition of rated voltage, electric and mechanical performance.

When life span exceeded the specified guarantee time of endurance and damp heat, electric characteristic might change and cause electrolyte insulation. This is called open circuit mode. It is recommended to use the capacitor at a lower temperature than the maximum temperature for the capacitor category.

8. Circuit design

Verify the following before designing the circuit:

- (1) The electrical characteristics of the capacitor will vary depending on differences in temperature and frequency. Only design your after verifying the scope of these factors.
- (2) When connecting two or more capacitors in parallel, ensure that the design takes current balancing into account.
- (3) When two or more capacitors are connected in series, variability in applied voltage may cause over-voltage conditions. Contact CapXon before using capacitors connected in series.

9. Capacitor usage environment

Do not use/expose capacitors to the following conditions.

- (1) Oil, water, salty water, take care to avoid storage in damp locations.
- (2) Direct sunlight
- (3) Toxic gases such as hydrogen, sulfide, sulfurous acids, nitrous acids, chlorine and chlorine compounds, bromine and bromine compounds, ammonia, etc.
- (4) Ozone, ultraviolet rays and radiation.
- (5) Severe vibration or mechanical shock conditions beyond the limits advised in the product specification section of the catalog.

10. Capacitor mounting

- (1) For the surface mount capacitor, design the copper pads on the PC board in accordance with the catalog or the product specification
- (2) For radial capacitors, design the terminal holes on the PC board to fit the terminal pitch of the capacitor.

11. Leakage current

Heat pressure from soldering and mechanical stress from transportation may cause the leakage current to become large. In such a case, leakage current will gradually decrease by applying voltage less than or equal to the rated voltage at a temperature within the upper category temperature. In close conditions to the upper category temperature, the nearer the applied voltage is to the rated voltage, the faster the leakage current recovery speed is.

Mounting precautions

1. Note

- (1) For the surface mount capacitor, design the copper pads on the PC board in accordance with the catalog or the product specification
- (2) For radial capacitors, design the terminal holes on the PC board to fit the terminal pitch of the capacitor.
- (3) Mount after checking the capacitance and the rated voltage.
- (4) Mount after checking the polarity.
- (5) Do not apply excessive external force to the lead terminal and the CP-CAP itself.
- (6) Ensure that the soldering conditions meet the specifications recommended by CapXon. Note that the leakage current may increase due to thermal stresses that occur during soldering, etc. Note that increased leakage currents gradually decrease when voltage is

applied.

2. Soldering using a soldering iron:

- (1) The soldering conditions (temperature and time) are within the ranges specified in the catalog or product specifications.
- (2) The tip of the soldering iron does not come into contact with the capacitor itself.

3. Flow soldering

- (1) Do not dip the body of a capacitor into the solder bath only dip the terminals in. The soldering must be done on the reverse side of PC board.
- (2) Soldering conditions (preheat, solder temperature and dipping time) should be within the limits prescribed in the catalog or the product specifications.

In regards to flow soldering, be sure to solder within the following conditions.

	Temperature	Duration	Flow number
Preheating	120°C or less (ambient temperature)	120 sec. or less	1 time
Soldering conditions	260+5°C or less	10+1 sec. or less	Twice or less

- (3) Do not apply flux to any part of capacitors other than their terminals.
- (4) Make sure the capacitors do not come into contact with any other components while soldering.

4. Reflow soldering

- (1) Soldering conditions (preheat, solder temperature and soldering time) should be within the limits prescribed in the catalogs or the product specification.
- (2) The heat level should be appropriate. (Note that the thermal stress on the capacitor varies depending on the type and position of the heater in the reflow oven.)
- (3) Vapor phase soldering (VPS) is not used.
- (4) Except for the surface mount type, reflow soldering must not be used for the capacitors.
- (5) In the case of reflow soldering, capacitive static electricity may decrease after soldering even when the soldering conditions are within the required values.
- (6) Recommended reflow condition of SMD type.

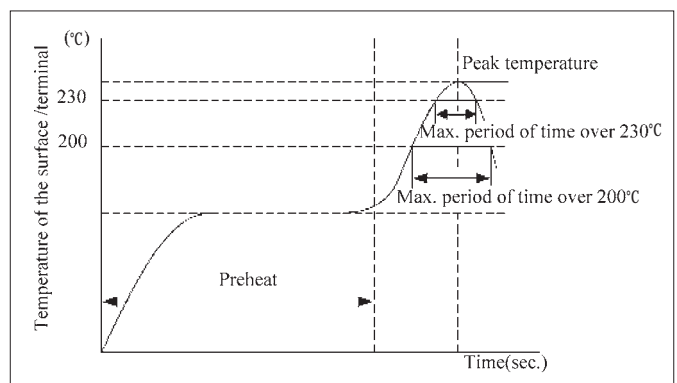

Voltage range	Preheat	Time maintained above 200°C	Time maintained above 230°C	Peak temp.	Reflow number
2.5 to 10v	150 to 180°C 120 sec. max.	90 sec. max.	60 sec. max.	260°C max	only 1 time
16 to 25v				90 sec. max.	60 sec. max.
		80 sec. max.	50 sec. max.	240°C max	twice or less
35 to 50v		70 sec. max.	30 sec. max.	240°C max	only 1 time

Note : 1) All temperatures are measured on the topside of the Al-case and terminal surface.
 2) The second reflow soldering shall be applied after the temperature of capacitors decreases down to the room temperature.

The leakage current value may increase (from a few μA to a few mA) even within the above conditions. When the CP-CAP is used in a DC circuit, the leakage current will decrease gradually through self-recovery after voltage is applied. If your reflow profile deviates from the above conditions for mounting the CP-CAP, please consult with CapXon.

5. Handling after soldering

Do not apply any mechanical stress to the capacitor after soldering onto the PC board.

- (1) Do not lean or twist the body of the capacitor after soldering the capacitors onto the PC board
- (2) Do not use the capacitors for lifting or carrying the assembly board.
- (3) Do not hit or poke the capacitor after soldering to PC board. When stacking the assembly board, be careful that other components do not touch the aluminum electrolytic capacitors.
- (4) Do not drop the assembled board.

6. Washing the PC boards

- (1) Do not wash capacitors by using the following cleaning agents. Solvent resistant capacitors are only suitable for washing using the cleaning conditions prescribed in the catalog or the product specification. In particular, ultrasonic cleaning will accelerate damage to capacitors.

- Halogenated solvents; cause capacitors to fail due to corrosion.
Alkali system solvents; corrode (dissolve) an aluminum case.
- Petroleum system solvents; cause the rubber seal material to deteriorate.
- Xylene; causes the rubber seal material to deteriorate.
- Acetone; erases the markings.

- (2) Verify the following points when washing capacitors.

- Monitor conductivity, pH, specific gravity and the water content of cleaning agents. Contamination adversely affects these characteristics.
- Be sure not to expose the capacitors under solvent rich conditions or keep capacitors inside a closed container. In addition, please dry the solvent

sufficiently on the PC board and the capacitor with an air knife (temperature should be less than the maximum rated category temperature of the capacitor) for 10 minutes. Aluminum electrolytic capacitors can be characteristically and catastrophically damaged by halogen ions, particularly by chlorine ions, though the degree of the damage mainly depends upon the characteristics of the electrolyte and rubber seal material. When halogen ions come into contact with the capacitors, the foil corrodes when a voltage is applied. This corrosion causes an extremely high leakage current which results venting and an open circuit.

Storage

The following conditions for storage are recommend.

- (1) Store capacitors in a cool, dry place. Store at a temperature between 5 and 35°C, with a humidity of 75% or less. SMD products are sealed in a special laminated aluminum bag. Use all capacitors once the bag is opened. Return unused capacitors to the bag, and seal it with a zipper. Be sure to follow our recommendations for reflow soldering.
- (2) Store the capacitors in a location free from direct contact with water, salt water, and oil.
- (3) Store in a location where the capacitor is not exposed to toxic gas, such as hydrogen sulfide, sulfurous acid, nitrous acid, chlorine or chlorine compounds, bromine or other halogen gases, methyl bromide or other halogen compounds, ammonia, or similar.
- (4) Store in a location where the capacitor is not exposed to ozone, ultraviolet radiation, or other radiation.
- (5) It is recommended to store capacitors in their original packaging wherever possible.

For Aluminum Electrolytic Capacitors

When you use aluminum electrolytic capacitors, remember the following.

1. Polarity

- Regular electrolytic Capacitor has polarity.
- Reverse voltage causes short circuit breakage of the capacitor or leakage of electrolyte. Where the polarity in a circuit sometimes reversed or unknown, a bi-polar capacitor should be used.

2. Overvoltage

- Do not apply overvoltage continuously.
- When overvoltage is applied to the capacitor, leakage current increase drastically.
- Applied working voltage to capacitors should not exceed the rated working voltage of capacitor.

3. Operating temperature and life:

- Do not use the capacitor over the max operating temperature.
- Life time of the capacitor depends on the temperature.
- Generally, life time is doubled by decreasing each temperature 10°C.
- Use temperature as low as possible.

4. Vent

- It is recommended at least 3mm of space around the vent.
- If such space is not provided, the vent will not operate completely.

5. Ripple current

- Do not apply a ripple current exceeding the rated maximum ripple current.
- Applying too much ripple current to the capacitor causes great heat generation, invites deterioration of properties of cases breakage.
- Please consult factory if ripple current exceeds the specified limit.

6. Charge and discharging

- Frequent and quick charge/discharge generates heat inside the capacitor, causing increase of leakage current, decrease of capacitance, or breakage occasionally.
- Consult us for assistance in this application.

使用鋁電解電容器注意事項：

1. 極性

鋁電解電容器一般是有極性的，極性反接是造成鋁電解電容器短路損壞及漏液的原因，因此在無法辨識電氣迴路上之極性或使用於有極性變換設計之迴路時，請選用無極性電解電容器。

2. 過載

請勿連續施加過載電壓。當電壓過載時電解電容器的漏電流會急速增加，所以電解電容器之工作電壓不應超過額定值。

3. 使用溫度和壽命

電解電容器之使用溫度請勿超出最高使用溫度之設定範圍。電解電容器的壽命取決於使用溫度，一般來說當電解電容器之使用溫度降低10°C時，其壽命將增為兩倍，因此電解電容器應儘可能在較低溫度下使用。

4. 防爆孔

有防爆孔設計之電解電容器其使用時防爆孔側應與其它機構保持最少3mm以上之空間距離，如此條件不能滿足的話，防爆孔將無法正常運作。

5. 紋波電流

請勿施加超過額定最高紋波電流容許值以上之紋波電流。施加過大紋波電流將使電解電容器的內溫異常上升，引起電解電容器電氣特性劣化及破損。如有需要施加額定值以上之紋波電流等要求時，請諮詢敝廠人員。

6. 充放電

經常及快速的充放電將使電容器之內溫異常上升，使漏電流增加、容量降低，有時還會造成產品之損壞，如對充放電有特殊要求時請諮詢敝廠人員。

7.Storage

- When the capacitor is stored for a long time without applying voltage, leakage current tends to increase.
- This returns to normal by applying the rated voltage to the capacitor before use.
- It is recommended to apply D.C. working voltage to the capacitor for 30 minutes through 1K Ω of protective series resistor, if it is stored for more than 6 months.
- The capacitor should be stored at a normal temperature and humidity.

8.Soldering

- Improper soldering may shrink or break the insulating sleeve and/or damage the internal element as terminals and lead wires conduct heat into the capacitor.
- Avoid too high a soldering temperature and/or too long a soldering time.

9.Mechanical stress on the lead wire and the terminal

- Do not apply excessive force to the lead wire and the terminal.
- Do not move the capacitor after soldering to the PC board, not carry the PC board by picking up the capacitor. For their strength, refer to JIS C-5141 and C-5102.

10.Cleaning of boards after soldering

- If the capacitor is cleaned in halogenated solvent for organic removing solder flux solvent, the solvent may penetrate into the inside of capacitor, and may generate corrosion.

11.Sleeve material

- The standard sleeve material is polyvinyl-chloride.
- If exposed to xylene, toluene, etc, and then subjected to high heat, the sleeve may crack. This sleeve is not insulating material.

12.CapXon's Products meet quality standards specified by JIS-C-5101-1 and the reliability requirements refer to JIS-C-5101-4(non-SMD liquid capacitor), -18(Liquid SMD capacitor), -25(solid SMD capacitor),-26(solid Radial capacitor).

13.None of ozone depleting chemicals (ODC) under the Montreal Protocol is used in manufacturing process of CapXon Electronic Industrial CO., Ltd.

7.電解電容器的儲存

當電解電容器經過長時間之放置後，通常其漏電流有增大之傾向。因此在使用經過長時間放置後之電解電容器以前，需先施加定額電壓使其電氣特性回復正常；如儲存時間長於6個月以上時，請串排1k Ω 之保護電阻後，使其持續負載定額工作電壓30分鐘。另外電解電容器應儲存於常溫及常濕之環境下。

8.焊錫

不適當的焊錫溫度及時間可能造成表面膠管之異常收縮破裂，有時高溫也會藉由導針及端子導熱至端子內部，對產品造成不良影響，因此須盡量避免過高溫度及過長時間之焊錫。

9.導針與端子之機械強度

請勿施加過度之外力於導針及端子上。請勿扳開已焊接於PC板上之電解電容器，更不要以電解電容器為施力點提起或移動整塊PC板。

10.焊錫後之基板清洗

如使用鹵化有機溶劑清洗基板，溶劑有可能滲進電解電容器內部引起腐蝕。

11.套管材料

一般使用之塑膠套膠材質多為聚氯乙烯(PVC)，如塑膠管在浸漬二甲苯或甲苯後再放置於高溫下，將產生破裂現象也同時失去了絕緣之功能。

12.本公司之產品品質符合JIS-C-5101-1指定標準，其信賴性試驗方法依JIS-C-5101-4(非SMD液態電容)，-18(液態SMD電容)，-25(固態SMD電容)，-26(固態導針型電容)之規範為基準。

13.本公司依蒙特利爾協議書之規定，於生產過程中不使用破壞臭氧層之藥品。